

# TRANSPALETA MANUAL CON 3 TONELADAS

de capacidad maxima  
AC30- ANCHA



### Valvula SELLADA

La valvula hidraulica sellada evita multiples aberias y asegura un funcionamiento optimo a largo plazo



### SISTEMA DE ELEVACIÓN

El sistema de elevación se realiza mediante una bomba hidráulica



### ESTRUCTURA RESISTENTE

Estructura construida en acero plegado que aporta una gran robustez.



### SISTEMA ANTIFATIGA

La comodidad es una de las características clave de este, ya que el mango estándar Eoslift / Soonlift con un diseño ergonómico de bucle reduce la fatiga de los operadores.

Marca	EOSLIFT EU/SOONLIFT
Modelo	AC30-ANCHA
Capacida de carga	3000 kg
Altura minima	8 cm
Altura maxima	20 cm
Tamaño de Horquilla	16 cm x 5,5 cm Ancho Alto
Separacion de uñas	68.5 cm
Largo de uñas	120 cm



+ Delivery Gratis



+ 12 meses de Garantia



+ Certificado de Operatividad

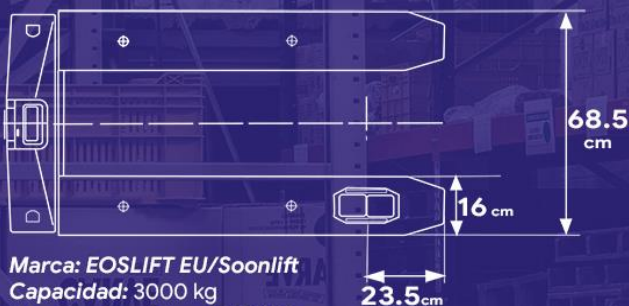

Marca: EOSLIFT EU/Soonlift

Capacidad: 3000 kg

Ruedas directrices: 85 X100

Ruedas traseras: 6 (3 x cada brazo 2 principales y 1 para estado de reposo)

Mando de válvulas: elevación, punto muerto, descenso.

Sistema Hidráulico sellado.

Material: Acero

Mango: Ergonómico de para evitar accidentes y fatiga

Referencia de calidad: Entre Distribuidoras de Alicorp por más de 10 años, en industria metalurgia, cementicia, construccion ,agroindustria, almacenes del puerto del callao, pesqueria ,etc.

Ruedas de nylon de tipo tándem.

Estructura reforzada

Soldadura robotizada.

Diseño contra sobrecarga

Tecnología Alemana

Garantía de 12 meses

### CERTIFICADOS ISO

EN ISO 12100:2010  
ISO 22915-4:2009+A  
1:2013

EN1175-1:1998+A 1:2010  
EN 349:1993+A 1:2008  
EN ISO 14120:2015  
EN ISO 13857:2008

Estándar:

En ISO 12100:2010  
ISO 22915-4:2009+A1:2013,  
EN 349: 1993+A1:2008,  
EN ISO 14120:2015,  
EN ISO 13857:2008



Telefono : 956 997 374  
www.panugtrading.com  
ventas@panugtrading.com

# Certificate of Compliance



No. 0B181024.SLEQ017

Test Reports no. SCC(18)-50010A-15-10-MD(1)

Certificate's  
Holder:

Soonlift Logistics Equipment Co., Ltd.  
No.166, Chengdong Road, Haiyan, Zhejiang,  
China, 314300

Certification ECM  
Mark:



Product:  
Model(s):

Hand Pallet Truck  
AC20, AC25, AC30, AC50, DF20, DF25, DF30,  
DF50, DF20E, ACL15, ACL20, ACLP10,  
ACLP20, I10, I15, I10D, I15D

Verification to:

Standard:  
EN ISO 12100:2010,  
ISO 22915-4:2009+A1:2013,  
EN 349:1993+A1:2008, EN ISO 14120:2015,  
EN ISO 13857:2008

related to CE Directive(s):  
2006/42/EC (Machinery)

**Remark:** The product(s) has been verified on a voluntary basis. The product(s) satisfies the requirements of the Certification Mark of ECM, in reference to the above listed Standard(s). The above Compliance Mark can be affixed on the product(s) accordingly to the ECM regulation about its release and its use. The regulation can be found at [www.entecerma.it](http://www.entecerma.it). This Certificate of Compliance can be checked for validity at [www.entecerma.it](http://www.entecerma.it)

This verification doesn't imply assessment of the production of the product(s).

Additional information, clarification about the **CE** Marking:



We attest that a TCF for the **CE** Marking process is in place. Whereas the Manufacturer is Responsible to start the **CE Marking Certification Procedure** and to perform all the necessary activities, as required by the Directive before placing the **CE** Mark on the product(s).

Date of issue 24 October 2018

Expiry date 23 October 2023

Chief Manager  
Matteo Morino

Deputy Manager  
Amanda Payne

Ente Certificazione Macchine Srl

Via Ca' Bella, 243 - Loc. Castello di Serravalle - 40053 Valsamoggia (BO) - ITALY  
 ☎ +39 051 6705141 📠 +39 051 6705156 ✉ info@entecerma.it 🌐 www.entecerma.it